

OptoSense AS

Sensor for Demand Controlled Ventilation (CO₂ and temp.)

Demand Controlled Ventilation with CO₂ measurement boosts energy efficiency in both new and refurbished buildings. The major savings are achieved in buildings with high standards for indoor climate and with large variations or low predictability in occupation.

The sensors from OptoSense yield a higher accuracy and better long term stability, resulting in excellent Indoor Air Quality with the lowest energy and operational costs.



High accuracy
Long term stability
No maintenance
Easy to install

Energy saving potential with Demand Controlled Ventilation

The energy saving potential in commercial and governmental buildings is enormous. This can be released through a lot of measures both in new and refurbished buildings; improved insulation, shielded façades, better windows, heat recovery etc. All this drive significant investments and yet it may be decremental to the indoor air quality.

Demand Controlled Ventilation based on CO₂ is cost effective and may be combined with all other measures to further increase the savings while maintaining an excellent indoor climate. Research throughout Europe show that as much as 50-60% of the energy usage to heating, cooling and circulation of air can saved with a well implemented and functioning DCV system.



«What you cannot measure, you cannot control!»

In order to release the full energy savings from DCV without compromising the indoor climate, accurate and stable measurements of CO₂ (and temperature) are needed. More so accuracy is required at all times and conditions; in all types of buildings, with varying occupancy patterns, 24/7 and throughout the lifespan of the building. This is what you get with the combined CO₂ and temperature sensors from OptoSense.

Demand to CO ₂ sensor	OptoSense fulfils due to	Other sensors may
Measurement accuracy better than +/- 30 ppm CO ₂ (and +/- 0,5°C) to adapt efficiently to the building load.	A robust and well balanced measurement system.	Lead to lower set-points and over-ventilation that marginalize the energy savings.
Stability throughout the lifespan of the building without maintenance.	Single path measurements with fixed moulded references.	Need regular calibration or adjustment upon changes in usage or floor layout.
Independence of continuous occupancy, variations in usage, seasonal BMS changes etc.	Measurement of absolute CO ₂ level independent of background concentration.	Not be used in buildings with 24/7 occupancy and may incur seasonal changes to indoor climate.

A sensor that meets these demands will also adapt to installation of heat exchangers, increased recycling of air, open windows during summer and minimum ventilation during winter. It will also make it possible to further increase energy savings through gradual improvements maintaining an excellent (and undisputed) indoor climate.

Value Creation

Value	Short term	Long term
To developer	Meet the demands in EU Directive on energy performance of buildings and achieve a better energy classification.	The building is prepared for higher energy prices and stricter regulation. Collect higher rates as energy cost attract more tenant focus..
To tenant	Lowered energy bill (up to 200 €/year per sensor) and less complaints on indoor climate.	Annual savings on energy. Increased productivity and general well-being among staff.
To HVAC subcontractor	Simple installation an commissioning.	Moving from a problem-driven to value driven post-sale market. From troubleshooter to energy consultant.

An example of calculated energy savings with various DCV setup:

OptoSense		DCV Energy savings calculator			
Area size in m2	85	Max persons	12	Operating hrs	14
Occupancy hours/day	> 90% 1	90%-50%	50-10%	< 10%	Total hrs 10
Vent. Heating	1	Vent.Cooling	1	Heat exchnge	1
DCV	Motion	Regular CO2	OptoSense	Nominal	
Fan kWh/year/m2	35	31	27	42	
Heat/Cool kWh/year/m.	46	40	33	57	
HVAC kWh/year/m3	81	71	60	99	
Savings kWh/year/m2	Motion	Regular CO2	OptoSense		
kWh/year	1 572	2 350	3 304		
€/year	189	282	397		
					225 work days 0,12 €/kWh



OptoSense IAQ Controller VAV

Based on the range of combined CO₂ and temperature transceivers OptoSense has developed a flexible room controller for Demand Controlled Ventilation that is easy to configure and install.

The controller has the following I/O:

- 2 regulator (0-10V) outputs to control VAV etc. Fully configurable with set-points for CO₂ and temperature level.
- Two relay outputs used to control heating and cooling sources or ventilation on/off, based on temperature or CO₂ level.
- 1 on/off input to use alternate controller scheme based on occupancy, night switch etc.
- 1 digital RS-485 Modbus line for set-up and monitoring purposes.

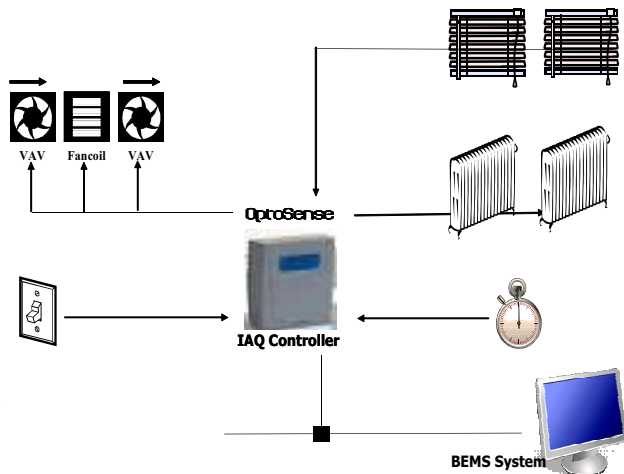

Windows setup examples:

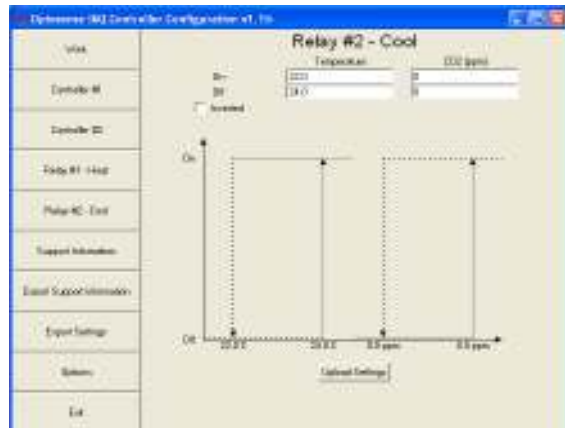
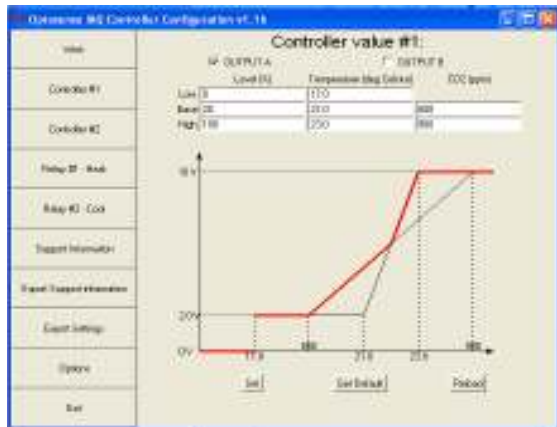

About OptoSense and the HoloChip technology

OptoSense is a Norwegian company that develops and sells micro-optical sensors for detection and measurement of various gases.

The unique and patented **HoloChip** technology bridge the gap between filter based sensors and spectrometers, providing accurate and stable measurements from a simple and cost-effective unit.

The current products measure Indoor Air Quality to ensure an excellent environment with minimum energy usage. The technology has also been demonstrated for industrial and medical applications.

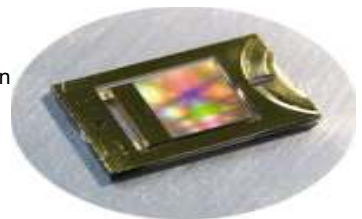

Product #	Product Name	Description
1-5-000001-01	OS IAQ Sensor VS	CO ₂ and temperature sensor, 0-10 V outputs, without display
1-5-000002-01	OS IAQ Sensor VD	CO ₂ and temperature sensor, 0-10 V outputs, with display
1-5-000003-01	OS IAQ Sensor CS	CO ₂ and temperature sensor, 4-20 mA outputs, without display
1-5-000004-01	OS IAQ Sensor CD	CO ₂ and temperature sensor, 4-20 mA outputs, with display
1-5-000006-01	OS IAQ Sensor VN	CO ₂ 0-10V output, passive temperature (NTC-20), without display
1-5-000005-01	OS IAQ Sensor Duct Kit	Duct mounting Kit for use with all the above sensors
1-5-000007-01	OS IAQ Sensor VP	CO ₂ and temp. 0-10 V output, with +/- 3 degrees offset adjustment
1-5-000008-01	OS IAQ Controller VAV	CO ₂ and temp., 2x0-10 V and 2xrelay outputs, 2xinputs, w. display

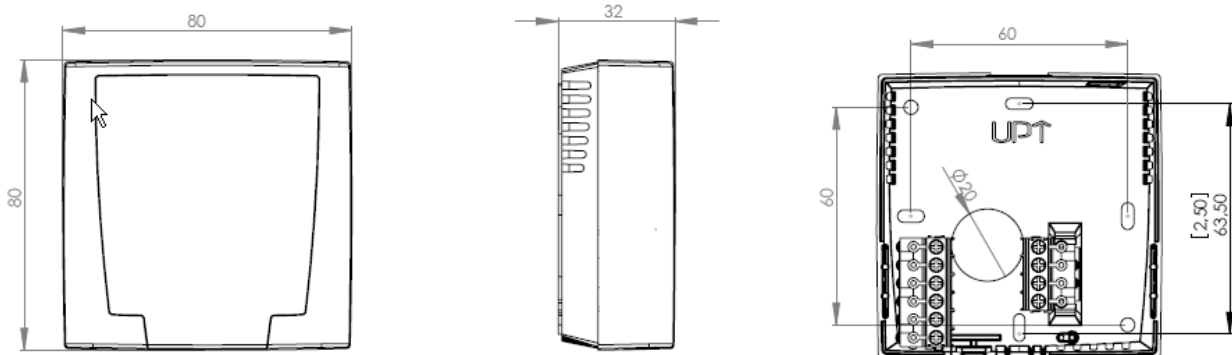

Better accuracy results in even lower energy bill Sensors from **OptoSense** react quickly and precisely so that a VAV system can provide an optimum indoor climate with less than 10% excess ventilation. This may lead to additional annual savings comparable to the cost of the sensor.

Independent of occupational pattern Sensors from **OptoSense** provide absolute and independent measurements throughout the lifetime, without any special set-ups or calibration routines. The sensors will measure correctly even if the building is in continuous use (365/24/7).

With a completely maintenance free solution Sensors from **OptoSense** continuously compares CO₂ measurements towards a fixed and balanced reference that compensates for any changes throughout the sensor life span. This means that **OptoSense** provides a completely maintenance free solution.

And simple installation Two steps: attach cables in back and go live by plugging in front with electronics. No special knowledge or skills required. The sensor will measure correctly from first minute without configuration or calibration that may introduce errors. The design is neutral and compact.

Key data	
Accuracy	CO ₂ < 30ppm(600–1200ppm), <50ppm(0-2000ppm) Temp. < 0,5 °C (10-40 °C)
Stability	< 4 ppm p.a.
Range	Standard: 0 – 2000 ppm og 0 – 50 °C
Power	AC: 20 - 30 V. DC: 16 to 38 V. Typical 500 mW
Life time	15 years without calibration or other maintenance

